

**Series 4, Built-in fridge-freezer with freezer at bottom, 177.2 x 54.1 cm, flat hinge
KIN86VFE0G**



The spacious built-in fridge-freezer combination with VitaFresh XXL and NoFrost keeps food fresh for longer and prevent ice formation.

- **VitaFresh XXL <0°C>**: keeps food fresh for longer in extra-large climate-controlled fridge drawers.
- **VitaFresh reduces wastage by keeping food fresh for longer.**
- **No Frost**: never defrost again, thanks to perfect protection from ice formation - that saves time and effort.
- **Cool Airflow**: maintains optimal air circulation and a constant temperature level throughout the cooling area.
- **Quiet appliances**: enjoy a calm and relaxing home.

Technical Data

Energy Efficiency Class ¹ : E
Average annual energy consumption in kilowatt hour per year (kWh/a): 234 kWh/annum
Sum of volume of frozen compartments: 76 l
Sum of volume of chill compartments: 184 l
Airborne acoustical noise emissions : 35 dB(A) re 1pW
Airborne acoustical noise emission class: B
Built-in / Free-standing: Built-in
Door panel options: Not possible
Height: 1772 mm
Width of the appliance: 541 mm
Depth: 548 mm
Required niche size for installation (HxWxD): 1775x560x550 mm
Net weight: 54.8 kg
EAN code: 4242005281374
Fuse protection: 10 A
Door hinge: Right reversible
Voltage: 220-240 V
Frequency: 50 Hz
Length electrical supply cord: 230 cm
Number of compressors: 1
Number of independent cooling systems: 1
Interior ventilator: No
Reversible Door Hinge: Yes
Number of Adjustable Shelves in fridge compartment: 2
Shelves for Bottles: Yes
Frost free system: Freezer
Installation typology: Integrated



¹ Scale of Energy Efficiency Classes from A to G

Series 4, Built-in fridge-freezer with freezer at bottom, 177.2 x 54.1 cm, flat hinge KIN86VFE0G

Additional features

- Net 4* compartment volume : 76 l

The spacious built-in fridge-freezer combination with VitaFresh XXL and NoFrost keeps food fresh for longer and prevent ice formation.

Design features

- easy Installation

Performance and Consumption

- EU19_EEK_D: E
- Total Volume : 260 l
- Net Fridge Volume : 184 l
- Net Freezer Volume : 76 l
- Freezing capacity 24h : 4 kg
- Annual Energy Consumption: 234 kWh/a
- Climate Class: SN-ST
- Noise Level : 35 dB , EU19_Noise emission class_D: B
- Temperature rise time : EU19_Temperature rise time_D: 10 H

Functions

- Bright interior LED fridge light in fridge section

Design features

- LED electronic control
- Super Cooling: automatic deactivation
- SuperFreeze function with automatic deactivation
- Optical and accoustical

Design features

- 4 safety glass shelves in fridge compartment of which 2 are height adjustable
- 1 removable door storage compartments.
- 3 door bins

Freshness System

- 1 VitaFresh drawer with humidity control - Fruits and vegetables retain vitamins and stay fresh for longer

Food freshness system

- NO_FROST_NEU_BL, never have to defrost ever again
- 3 freezer drawers

Dimension and installation

- Dimensions: 177.2 cm H x 54.1 cm W x 54.8 cm D
- Niche Dimensions: 177.5 cm H x 56 cm W x 55 cm D

Key features - Fridge section

- Right hinged door, door reversible
- 220 - 240 V

Key features - Freezer section

- 1 x ice cube tray

Country Specific Options

- Based on the results of the standard 24-hour test. Actual consumption depends on usage/position of the appliance.

Series 4, Built-in fridge-freezer with freezer at bottom, 177.2 x 54.1 cm, flat hinge KIN86VFE0G

measurements in mm

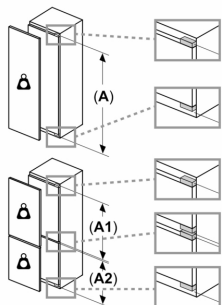
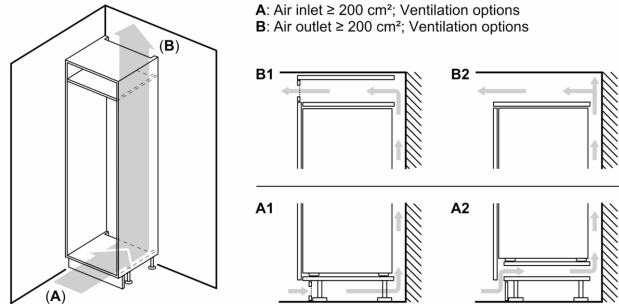
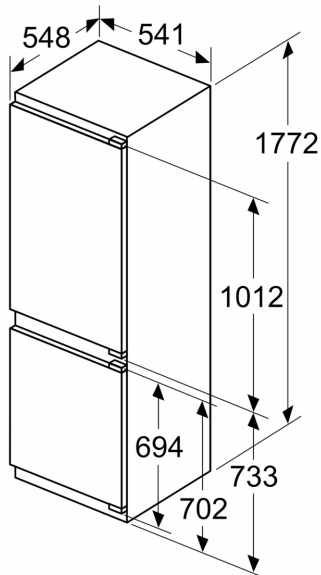

Maximal permissible weight of the unit fronts

Fitted unit fronts that exceed the permissible weight may cause damage and result in functional impairment of the hinges

Δ Weight
 A: Appliance door height including hinges in mm

B: Undamped hinge, unit front in kg

C: Damped hinge, unit front in kg

D: Additional possible load in kg with heavy load kit

A	B	C	D
1500-1750	22	22	
720-1400	19	19	B+5 / C+5
A1	15	19	
A2	15	19	

Measurements in mm

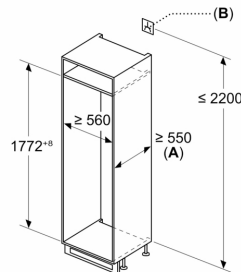

A: $\geq 560 \text{ mm}$ (recommended)

B: Socket

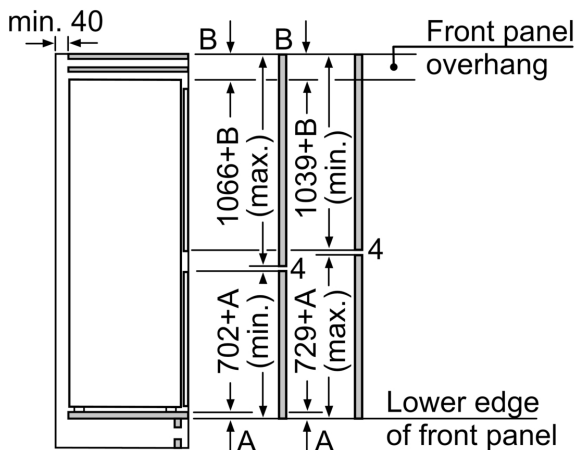

measurements in mm

Recommended gap dimensions for flat hinges

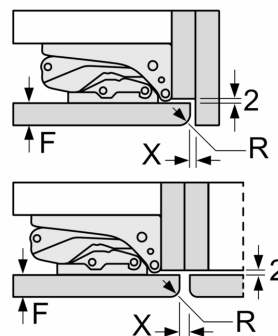

F	R	X
16-19	0-3	2.5
20	0-1	3
21	2-3	2.5
	0-1	3
22	2-3	2.5
	0	4
	1	3.5
	2-3	3

The specified unit door dimensions are valid for a door gap of 4 mm.

measurements in mm

The gap dimensions recommended in the table must be adhered to in order to ensure that appliance doors do not collide with anything when they are opened, and to avoid causing damage to kitchen units.