

**Series 2, Built-in fridge-freezer with freezer at bottom, 193.5 x 54.1 cm, sliding hinge  
KIN96NSE0G**



**The extra large built-in fridge freezer with 12% more cooling volume including Multi Box XXL drawer for fruit and vegetables, No Frost and error warning signal for optimal storage.**

- **Built-in XL:** get 11% extra volume of storage\* thanks to a taller design.
- **MultiBox XXL:** extra-large drawer for your fruit and vegetables.
- **No Frost:** never defrost again, thanks to perfect protection from ice formation - that saves time and effort.
- **Quiet appliances:** enjoy a calm and relaxing home.
- **Cool Airflow:** maintains optimal air circulation and a constant temperature level throughout the cooling area.

**Technical Data**

Energy Efficiency Class <sup>1</sup> :	..... E
Average annual energy consumption in kilowatt hour per year (kWh/a):	..... 231 kWh/annum
Sum of volume of frozen compartments:	..... 75 l
Sum of volume of chill compartments:	..... 215 l
Airborne acoustical noise emissions :	..... 34 dB(A) re 1pW
Airborne acoustical noise emission class:	..... B
Built-in / Free-standing:	..... Built-in
Door panel options:	..... Not possible
Height:	..... 1935 mm
Width of the appliance:	..... 541 mm
Depth:	..... 548 mm
Required niche size for installation (HxWxD):	..... 1940x560x550 mm
Net weight:	..... 55.0 kg
EAN code:	..... 4242005512911
Fuse protection:	..... 10 A
Door hinge:	..... Right reversible
Voltage:	..... 220-240 V
Frequency:	..... 50 Hz
Length electrical supply cord:	..... 230 cm
Number of compressors:	..... 1
Number of independent cooling systems:	..... 2
Interior ventilator:	..... No
Reversible Door Hinge:	..... Yes
Number of Adjustable Shelves in fridge compartment:	..... 4
Shelves for Bottles:	..... No
Frost free system:	..... Freezer
Installation typology:	..... Integrated



<sup>1</sup> Scale of Energy Efficiency Classes from A to G

## Series 2, Built-in fridge-freezer with freezer at bottom, 193.5 x 54.1 cm, sliding hinge KIN96NSE0G

**The extra large built-in fridge freezer with 12% more cooling volume including Multi Box XXL drawer for fruit and vegetables, No Frost and error warning signal for optimal storage.**

- NoFrost freezer, Built-in fridge-freezer
- Sliding hinge, softClosing door: No

### Performance and Consumption

- EU19\_EEK\_D: E
- Total Volume : 290 l
- Annual Energy Consumption: 231 kWh/a
- Noise Level : 34 dB , EU19\_Noise emission class\_D: B

### Functions

- Bright interior LED fridge light in fridge section
- Built-in fridge-freezer

### Design features

- NO\_FROST\_NEU\_BL, never have to defrost ever again
- EU19\_Fast freezer facility\_D
- Separate, electronic temperature control with LED display
- Super Cooling: automatic deactivation
- Optical and accoustical
- Automatic defrost fridge

### Design features

- Net Fridge Volume : 215 l
- 5 safety glass shelves in fridge compartment of which 4 are height adjustable
- Door shelves in fridge door: 1 large and 3 small.

### Freshness System

- 1 MultiBox - Transparent drawer with a rippled bottom, ideal for storing fruits and vegetables.

### Food freshness system

- Net Freezer Volume : 75 l
- Freezing capacity 24h : 7.5 kg
- Temperature rise time : EU19\_Temperature rise time\_D: 10 H
- 3 freezer drawers

### Dimension and installation

- Dimensions: 193.5 cm H x 54.1 cm W x 54.8 cm D
- Niche Dimensions: 194 cm H x 56 cm W x 55 cm D

### Key features - Fridge section

- Right hinged door, door reversible
- Length of power cord: 230 cm
- Climate Class: SN-ST
- 220 - 240 V

### Key features - Freezer section

- 1 x ice cube tray

### Country Specific Options

- Based on the results of the standard 24-hour test. Actual consumption depends on usage/position of the appliance.

### Design features

### Dimension and installation

### Additional features

- none

**Series 2, Built-in fridge-freezer with  
freezer at bottom, 193.5 x 54.1 cm,  
sliding hinge  
KIN96NSE0G**

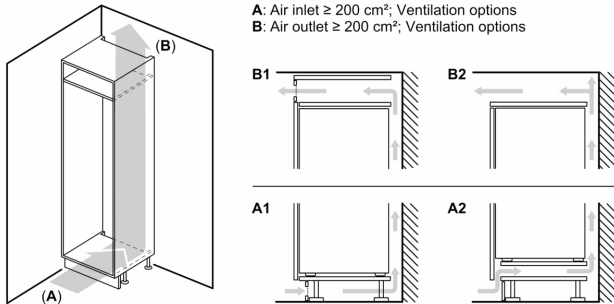

**Measurements in mm**

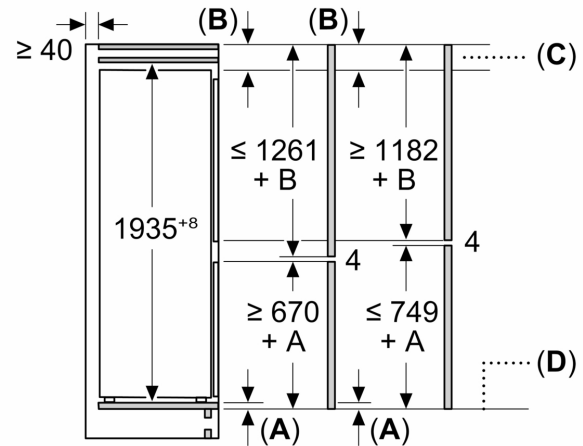

**C:** Front panel overhang

**D:** Lower edge of front panel

**Measurements in mm**

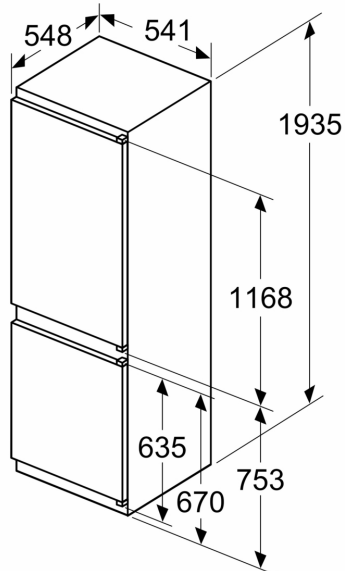

**Measurements in mm**

